

Pulper Gearbox

BENEFITS

- Increased gearbox life
- Increased pulper uptime
- Reduced maintenance costs
- Easy installation
- Reduced lubricant costs

FEATURES

- Unitized construction
- Flange mounting
- External drain lines
- VBXX interface
- VBX o-ring
- Shaft alignment skates
- Available split or solid
- Available with air purge



INPRO/SEAL[®]
COMPANY

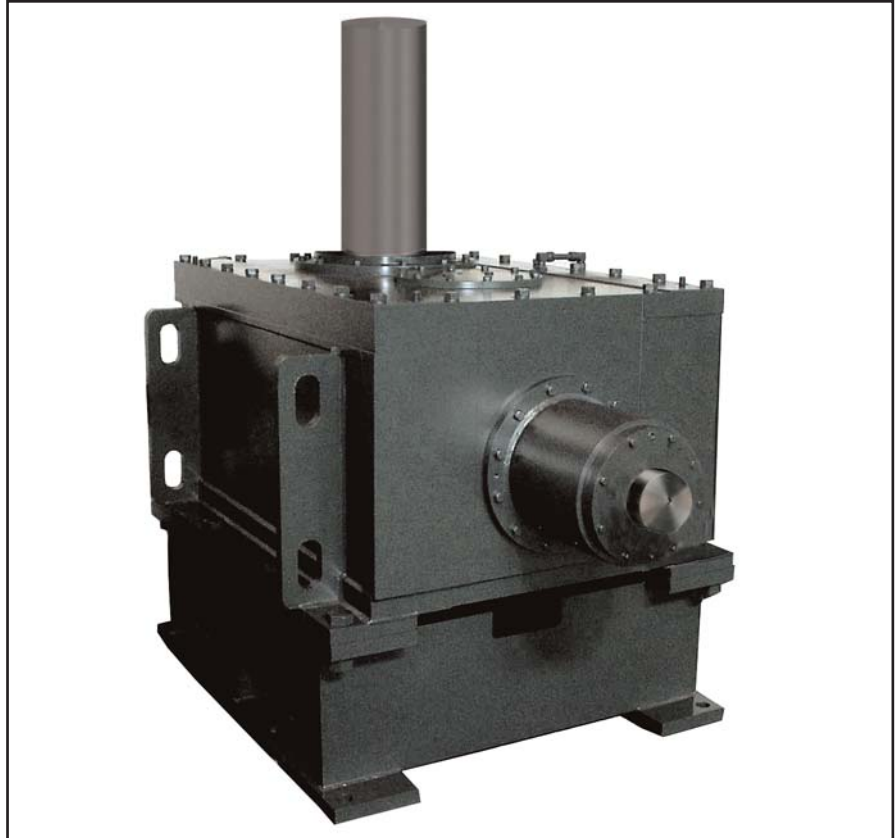

Inpro/Seal[®] Pulper Drive Bearing Isolator (PDI)

There is no longer any need for extreme measures to keep the water and paper stock out of your pulper gearboxes. Expensive oil filter systems, gearbox air purge systems and oil sampling are not necessary. Inpro/Seal's new Heavy Duty Pulper Gearbox Bearing Isolator is specifically designed to combat the severe environments found in the Paper Industry.

Installation is easy because each Bearing Isolator is custom designed and built for your specific equipment with solid and split options available.

Prevent extended downtime and difficult removal and rebuild of your Pulper Gearboxes with Inpro/Seal[®].

Pulper Gearbox

Pulper Air Purge Design

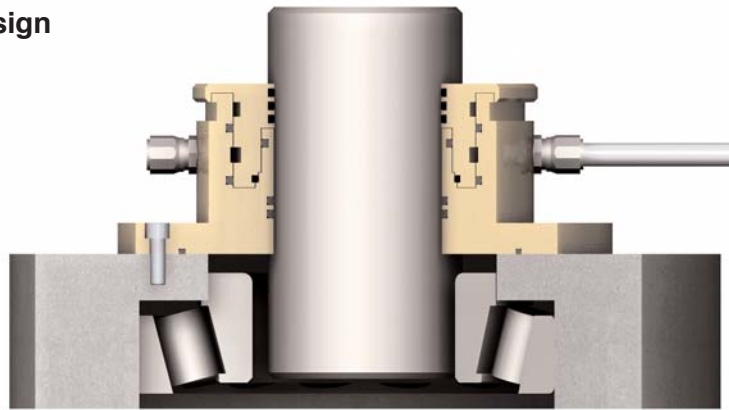

Pulper Design

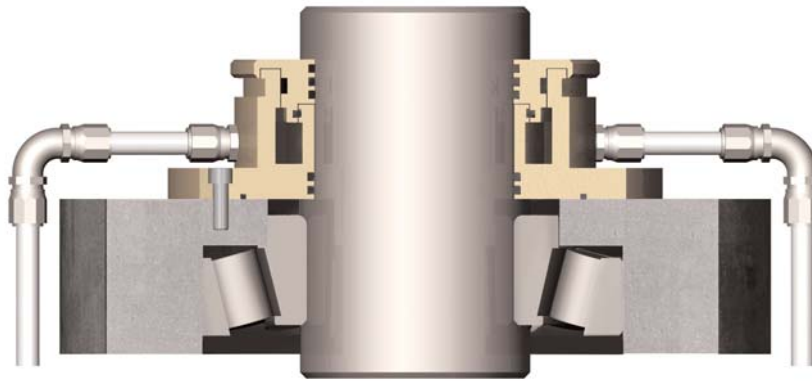

Request For Quote

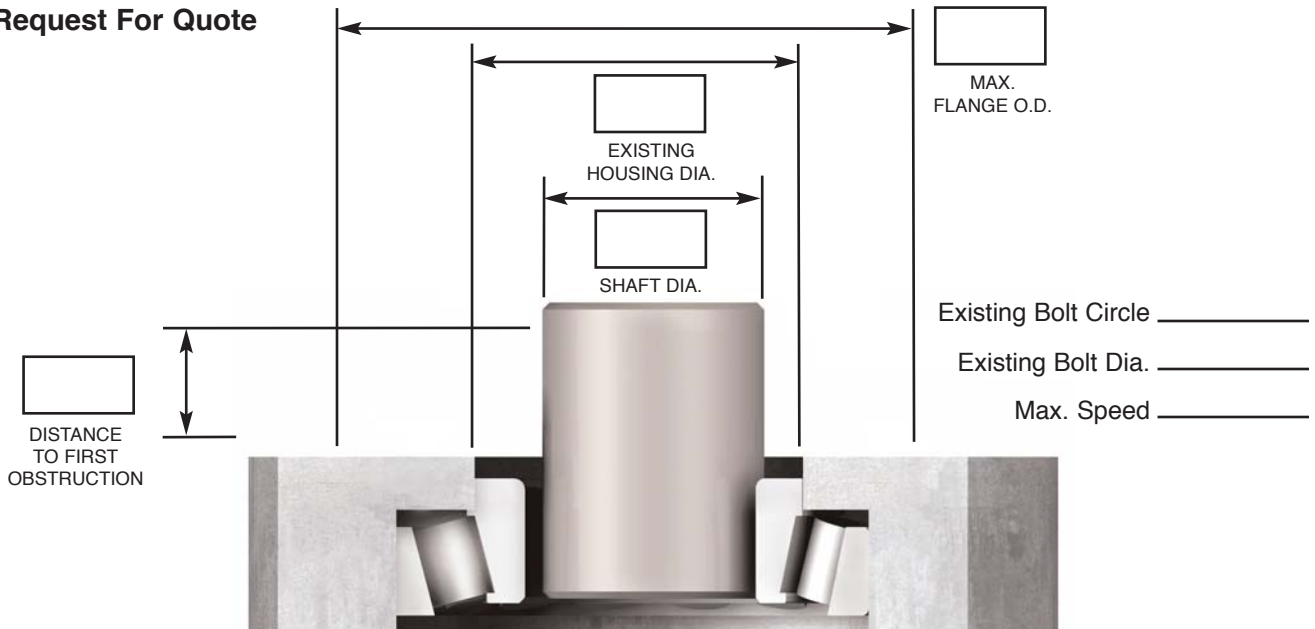

Form # 4.3.038 REV. ORG.



Same Day Shipments
 Over 2,500,000 Installed
www.inpro-seal.com



Inpro/Seal Company
#1 In Bearing Isolators

4221-81st Avenue West • Rock Island, IL 61201
 Ph: 309.787.4971 • 800.447.0524 • Fax: 309.787.6114 • 309.787.6190
 e-mail: info@inpro-seal.com • Visit us on the web: www.inpro-seal.com